

Grid Network Interface (GNI)

Georgios Zervas
Tomohiro Kudoh
Eduard Escalona

University of Essex
AIST
University of Essex

Grid Network Interface (GNI) BOF Agenda



- Presentation on target, scope and aim of GNI-WG
 - BOF Organizers
- Presentation from current activity participants
 - Interfacing Grids and NRPSes (i2cat representative)
 - DRAC APIs and approach (Inder Monga, Nortel)
 - DICE Control Plane (John Vollbrecht, Internet2)
 - GNI for next-gen telecom services (Takahiro Miyamoto, KDDI R&D labs.)
- Discussion:
 - Charter review
 - Deliverables & Milestones
 - Activities and synergies with DMNR BOF
 - Election of Chairs
 - Action Points

Talk Overview



- Need for GNI
- GNI History
- GNI Aim and Scope
- GNI Reference Point
- GNI Charter
 - Deliverables and Milestones
- GNI Design choices
 - Current Standardization activities relevant to GNI

Need for GNI



- Evolving Grid Network Architectures:

Grid

- Grid user
- Grid middleware
 - Grid Service Provider
 - » co-allocation services, Brokers, etc.

Network

- Network Service Provider
 - Network Services
 - » Network Resource Provisioning Systems (ARGIA/UCLP, ARGON, DRAC, etc.)
 - » Control plane (e.g. GMPLS)

- An **interface** with generic definition, independent of implementation solutions is required to provide interoperability between Grid and Network.

GNI history



- Activity started around 3 years ago
- Three Continent Collaboration (C3C)
 - G-lambda – GNS-WSI
 - Enlightened
 - Phosphorus
- GUNI Informational Draft in OGF (GHPN-RG)
- GLIF Control Plane Working Group
 - GLIF Generic Network Interface Task Force
 - **Analysis and draft of the GNI Interface**
- Common Effort and agreement between OGF and GLIF GNI activities

- **Europe**
 - IST-Phosphorus
 - UEssex (G. Zervas, E. Escalona, R. Nejabati, D. Simeonidou)
 - NXW (N. Ciulli, G. Carrozzo)
 - PSNC (A. Binczewski, D. Parniewicz, B. Belter)
 - FHG (O. Waeldrich, W. Ziegler)
 - I2cat (Sergi Figuerola)
 - IST EC-GIN
 - CARRIOCAS
 - INRIA (Pascale Primet)
 - Alcatel-Lucent Bell Labs (Dominique Verchere)

GNI existing contributors II



- **USA**
 - Enlightened
 - MCNC, Research & Development Institute (Gigi Karmous-Edwards)
 - NORTEL (Inder Monga)
- **Japan**
 - G-lambda
 - AIST (Tomohiro Kudoh, Atsuko Takefusa, et.al)
 - KDDI R&D Labs (Takahiro Miyamoto, Michiaki Hayashi, et.al)
 - NTT (Yukio Tsukishima, Yasunori Sameshima, et.al)
 - NICT (Shinji Shimojo, Hideki Otsuki)
- **China**
 - 3TNET (SJTU- Wei Guo)
- **GLIF**
 - GNI Task Force

Grid Network Interface: Scope



- Facilitate interoperation between **Grid** and **Network** infrastructures *via the recommendation and creation of standard functionalities and procedures.*
- Define the set, type and level of information transaction between Grid-Network interaction.
- Provide a general and open definition **independent from any implementation of provisioning system** (e.g. Grid and network).

Grid Network Interface: Aim



- Create an abstract and scalable architecture to facilitate any future requirements.
- Identify existing standardization activities/documents and understand their relevance and way to adopt them towards GNI standardization.
- Provide GNI as a recommendation to any Grid and network system in order to achieve seamless Grid Network Service (GNS) interoperability.

Grid Network Interface: Interoperability-Issue

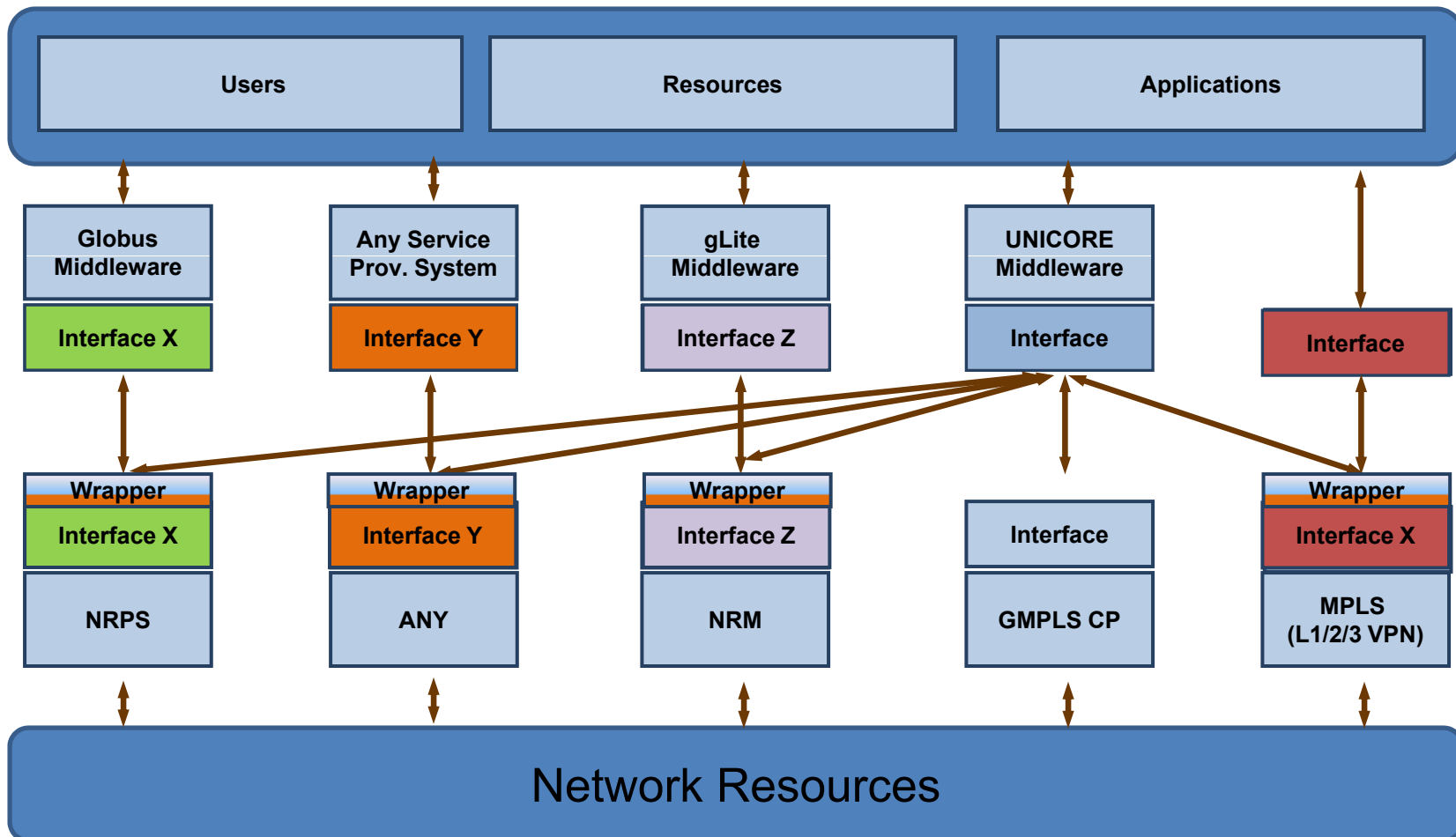

Grid Network Interface: Interoperability-Aim

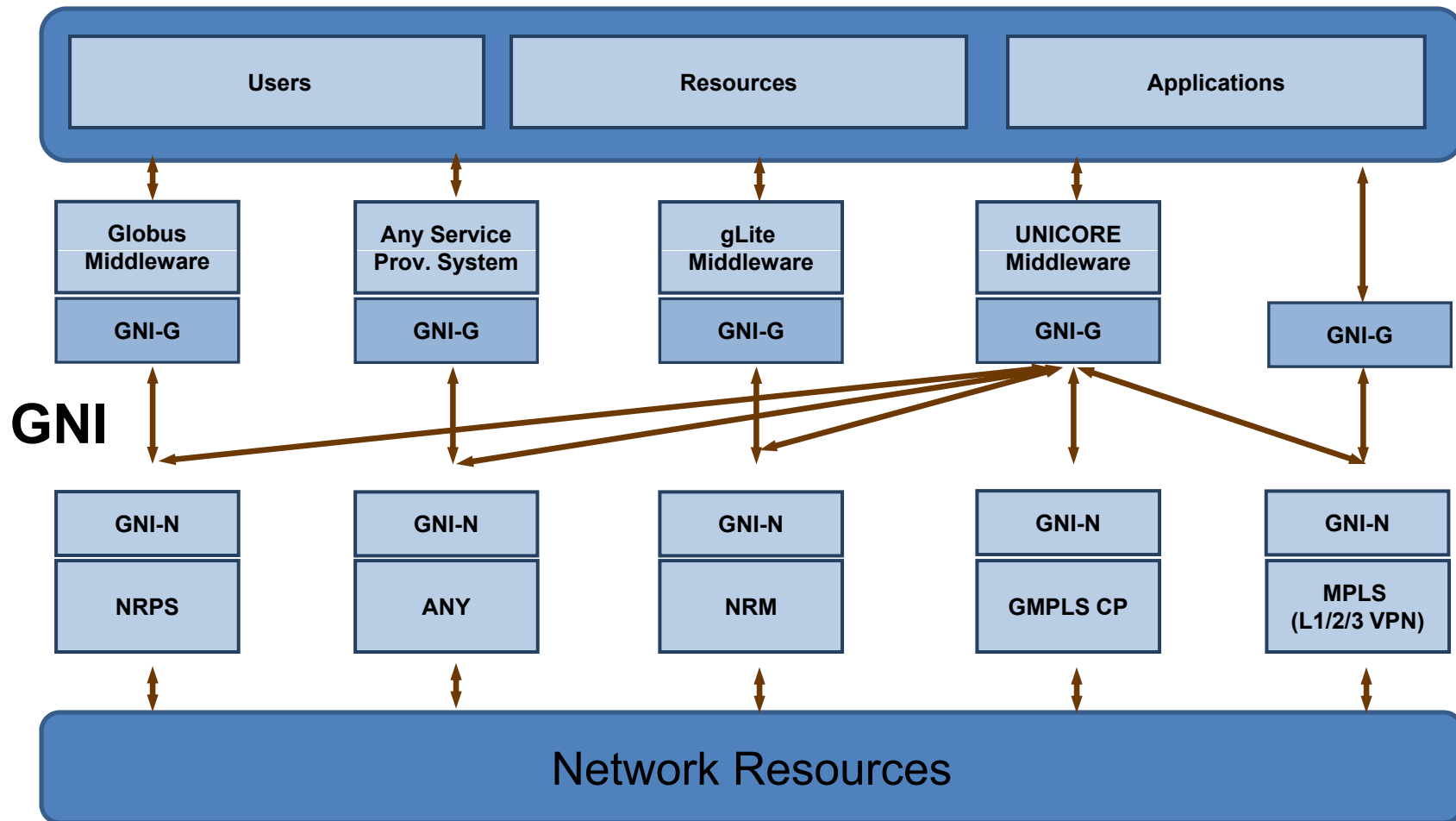

Tree Model, Chain Model and GNI

- Middleware to Network Interface is the GNI

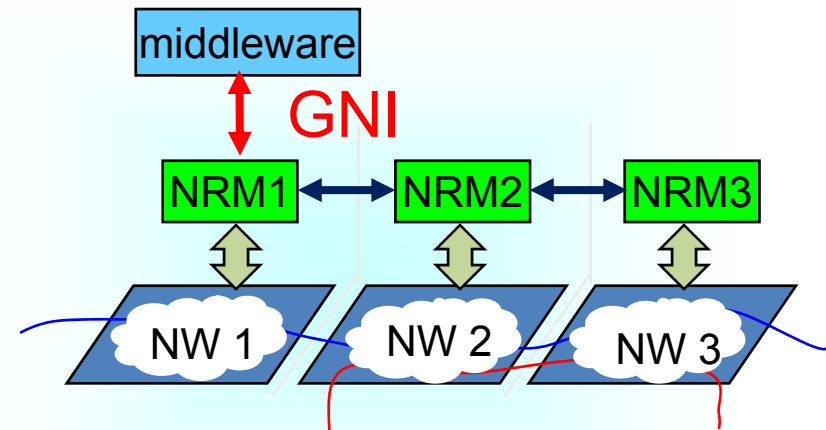
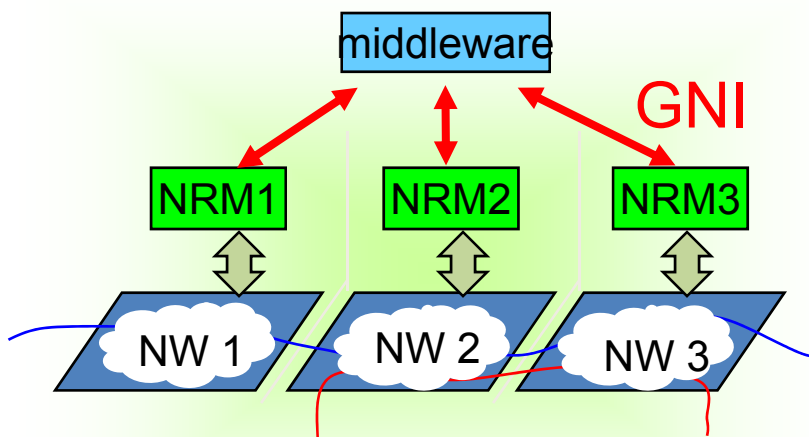

GNI-WG Charter I



Draft Charter for GNI-WG

Date 2008-05-06

Group Abbreviation:

gni-wg

Group Name:

Grid Network Interface working group

Area:

Infrastructure

Group Leadership:

Georgios Zervas

Tomohiro Kudoh

Eduard Escalona

Group Summary:

The Grid Network Interface working group will provide a recommendation for an interface between Grid layer and Network layer. The interface will define the set, type and level of information transaction between these two layers as well as procedures and protocols required for it.

GNI-WG Charter II



Charter Focus/Purpose and Scope:

Focus/Purpose

The main purpose of the GNI is to facilitate interoperation between Grid and Network infrastructures via the development of functionalities and procedures. GNI must provide a general and open definition independent from implementation of provisioning systems (e.g. Grid and network). It should be abstract and scalable enough to facilitate any future requirements. So, GNI will be a recommendation to any Grid and network system in order to achieve interoperability. GNI WG will also focus on identifying existing standardization activities/documents and understand their relevance and importance with regards to GNI.

Goals

The goal of the GNI-WG is to provide a specification document with the requirements and capabilities of both Grid applications/ services as well as network provisioning systems (e.g. network operators, L1/2/3 systems) and in turn define the architecture and abstract GNI messages. Definition and creation of abstract message transactions of the GNI based on the architecture will be another goal.

The scope of the Grid Network Interface Working Group is to define the following:

- a) architecture definition for GNI
- b) abstract messages and procedures independent of any implementation

The working group will collaborate with other OGF working groups such as GRAAP, NML, and others where these are considered relevant and applicable.

Deliverable 1.

Title: Grid Network Interface architecture and functionality requirements

- Description: A recommendation document describing the architecture for functionalities required to structure the GNI.
 - Define GNI architecture
 - Identify requirements for Grid applications, Middleware and Network providers
 - Specify GNI functionalities.

Deliverable 2.

Title: Grid Network Interface Specification Document

Description: A recommendation document describing GNI protocol and messages specification.

- Abstract Message Definition and Protocol Specification of
- Service Discovery
 - Capability, Availability
- Network Service Request (type of service, policies, AAA)
 - Connection Creation
 - Point-to-Point, Point-to-Multipoint, Multipoint-to-Multipoint,
 - Source, Destination, Bandwidth, SLA, Start-Time, End-Time, delay, jitter, etc...
 - Connection Deletion
 - Connection Modification
- Connection monitoring

Milestones -Timeline



- OGF 24 (Sep 2008):
 - official start of working group
 - outline and author list of deliverables
- OGF 25 (Feb 2009):
 - First Draft of Deliverable 1
- OGF 26 (Jun 2009):
 - Submission of Deliverable 1, First Draft of Deliverable 2
- OGF 26 (Jun 2009):
 - Update of Deliverable 2
- OGF 27 (Sep 2009):
 - Submission of Deliverable 2

Grid application requirements



- Network Capability/Discovery Service
 - Grid Service Provider can query the network capabilities like bandwidth, latency between the various end points so it can adjust its send and receiving buffers to smooth out the traffic at the expense of latency.
- Network Resource Allocation Service
 - The GSP might need to allocate the right Quality of Service (QoS) including bandwidth, latency, priority between the different visualization session locations.
- Network Monitoring Service
- Network Advanced Reservation Service
 - This service might be used to monitor the ongoing network QoS and prompt the Grid Service Provider, and in turn the application, in case the SLA negotiated is violated.
- Network Security Service
- Network AAA Service
 - The Grid Service Provider might need Authorization before allocating network

Collaboration with existing WGs



- OGF Working/Research Groups
 - NML-WG
 - GRAAP-WG
 - NM-WG
 - GHPN-RG
 -
- GLIF Control Plane Working Group
 - GLIF Generic Network Interface Task Force

All invited to participate on GNI-WG!

Any Questions?