

EDGeS

**Enabling Desktop Grids for e-
Science
FP7 Capacities project**

P. Kacsuk, MTA SZTAKI

G. Terstyanszky, University of Westminster



The EDGeS project receives Community research
funding





The problem the EDGeS project address

- There are **service grids** (SG):
 - Guaranteed service based on clusters but
 - Relatively small number of processors (1K -50K)
 - Many users but misuse the resources
 - Most of the applications are parameter sweep applications that better fit to desktop grids
 - Take away the cluster resources from MPI type applications
- There are **desktop** (or volunteer) **grids** (DG):
 - No guaranteed service but
 - Large number of processors (100K – 1M)
 - Few users: 1-3 projects per desktop grid



Enabling Desktop Grids for e-Science (EDGeS)

- EDGeS as a new FP7 project started on the 1st of January 2008
- Goals of the project:
 - To integrate Service Grids and Desktop Grids to attract new scientific communities that needs very large number of computing resources (100K-1M processors)
 - To enable the seamless usage of the integrated SG-DG infrastructure, i.e. the user does not need to be aware if the application is executed in SG or DG
 - To provide a Grid application development environment including testing and validation
 - To provide application repository and broker for the seamless execution of applications in the SG-DG system



Project partners

| Partic. No. | Participant name | Participant short name | Country |
|-------------|---|------------------------|-----------------|
| 1 | Computer and Automation Research Institute of the Hungarian Academy of Sciences | MTA SZTAKI | Hungary |
| 2 | Centro de Investigaciones Energéticas Medio Ambientales y Tecnológicas | CIEMAT | Spain |
| 3 | Foundation for the Development of Science and Technology in Extremadura | Fundecyt | Spain |
| 4 | The French National Institute for Research in Computer Science and Control | INRIA | France |
| 5 | University of Westminster | UoW | UK |
| 6 | Cardiff University | CU | UK |
| 7 | Faculty of Sciences and Technology of the University of Coimbra | FCTUC | Portugal |
| 8 | Stichting AlmereGrid | AlmereGrid | The Netherlands |
| 9 | Centre National de la Recherche Scientifique - Institut National de Physique Nucleaire et de Physique des Hautes Energies | IN2P3 | France |



Structure for the DG->EGEE bridge: phase I - gliding

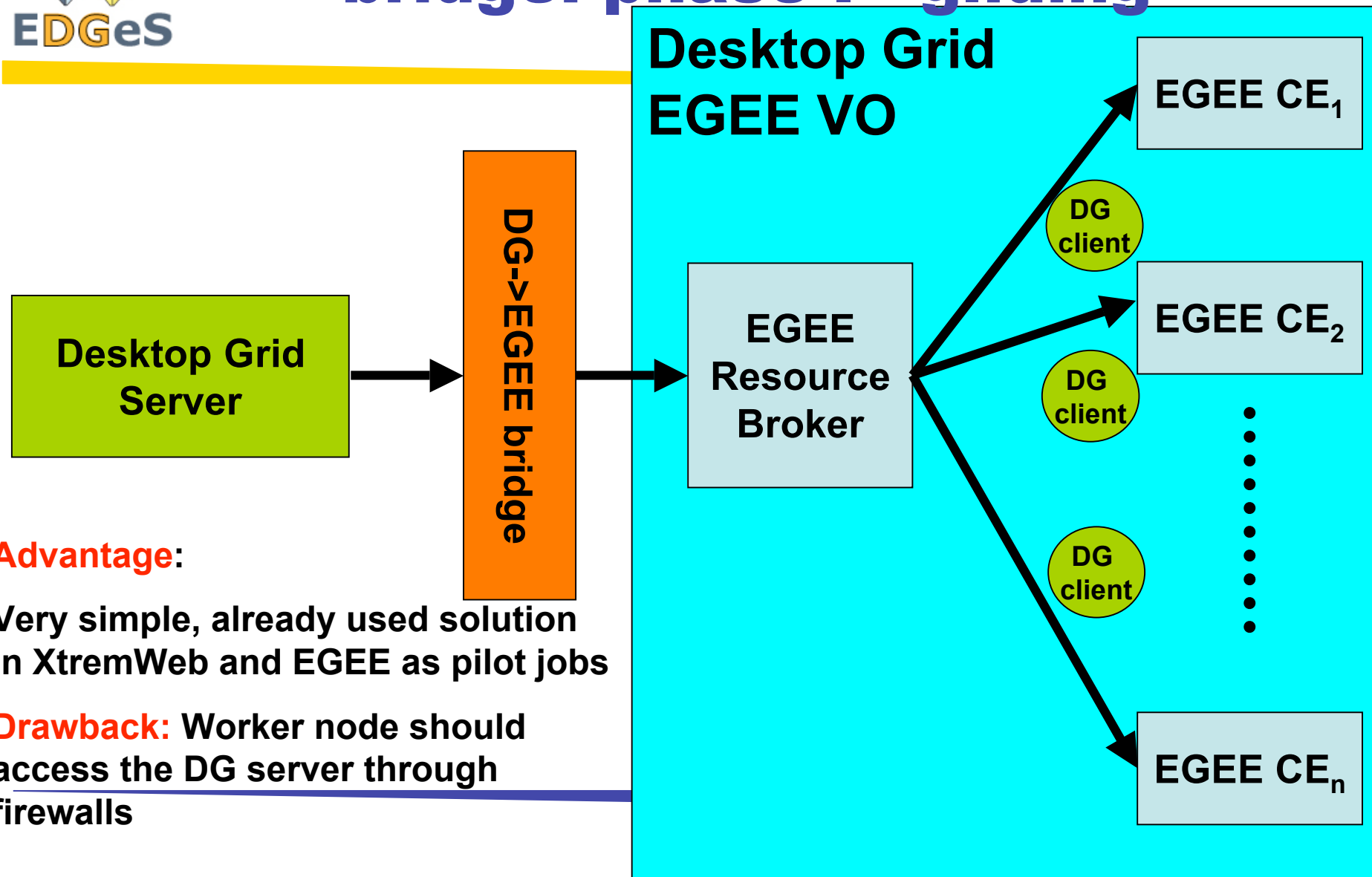



Structure for the DG->EGEE bridge: phase II

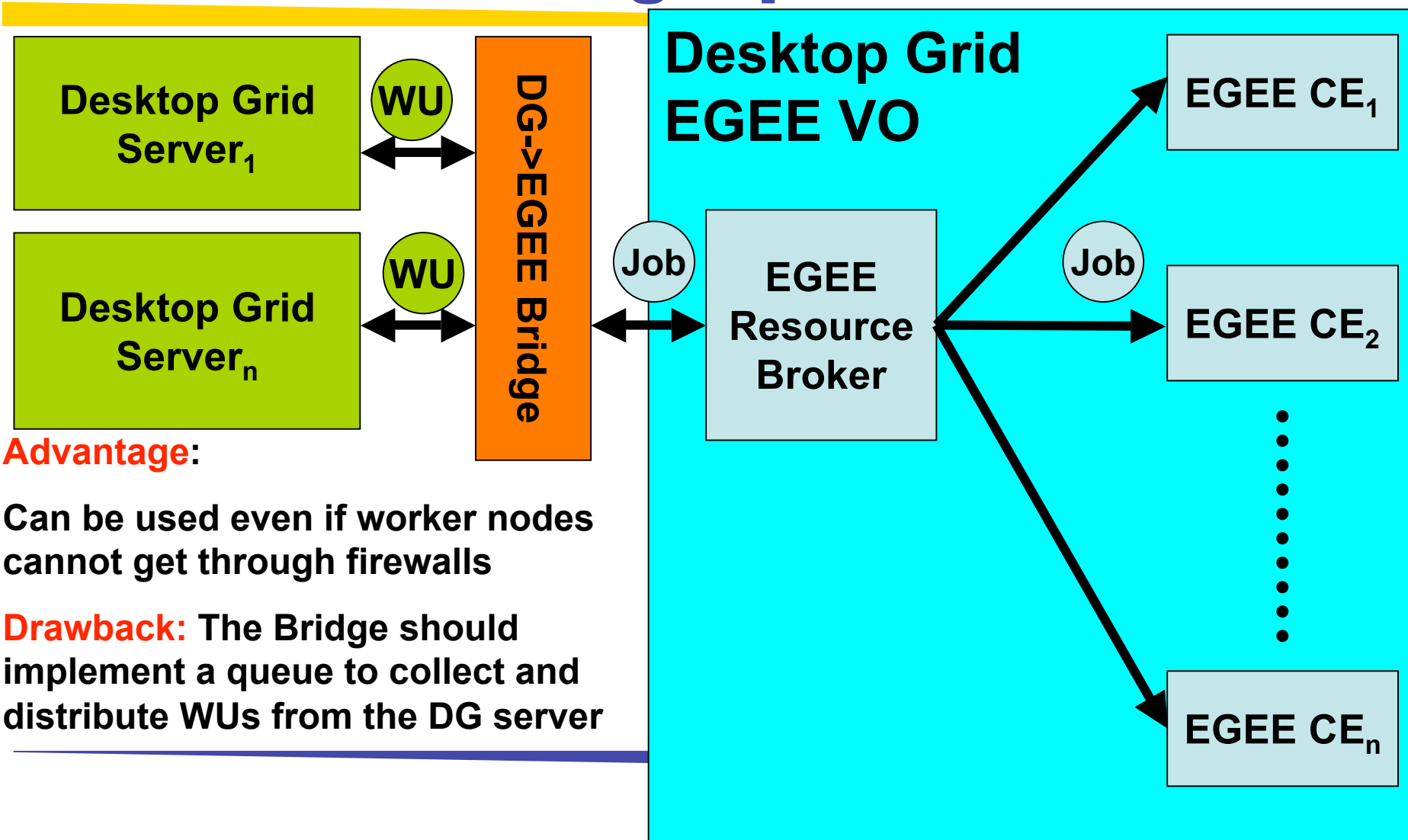

Advantage:

Can be used even if worker nodes cannot get through firewalls

Drawback: The Bridge should implement a queue to collect and distribute WUs from the DG server



EGEE-> DG bridge

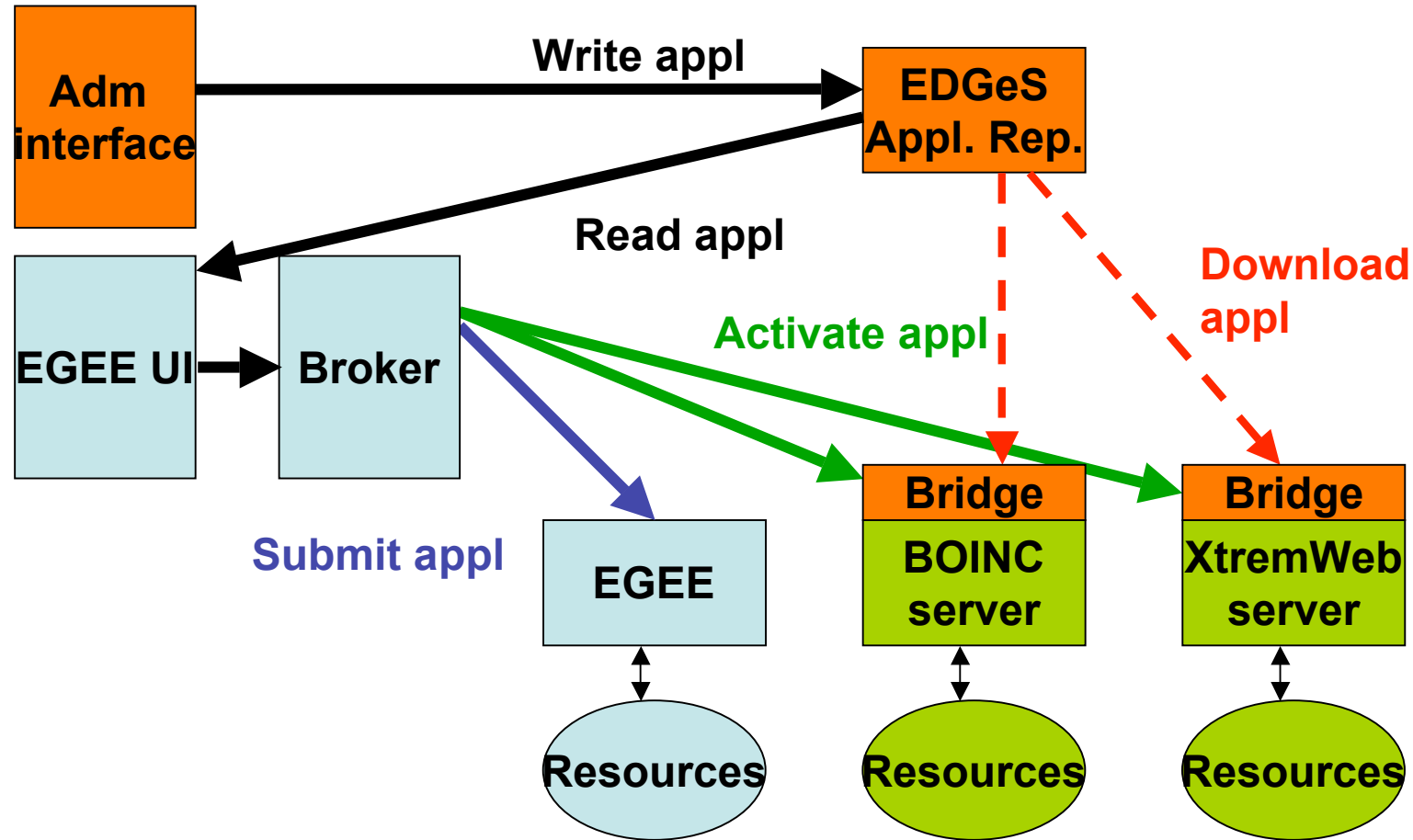

Detailed architecture

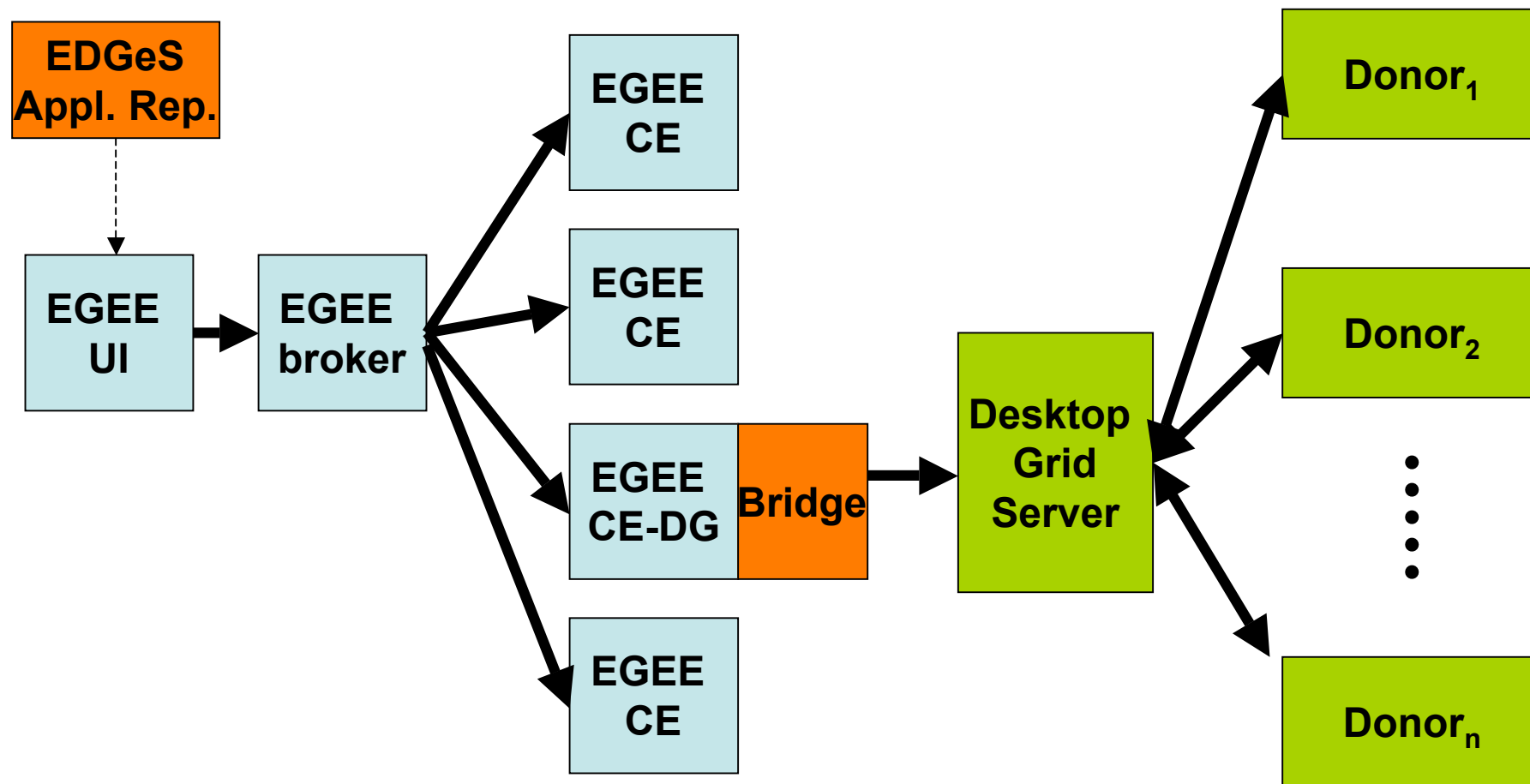



EDGeS

The EDGeS production infrastructure

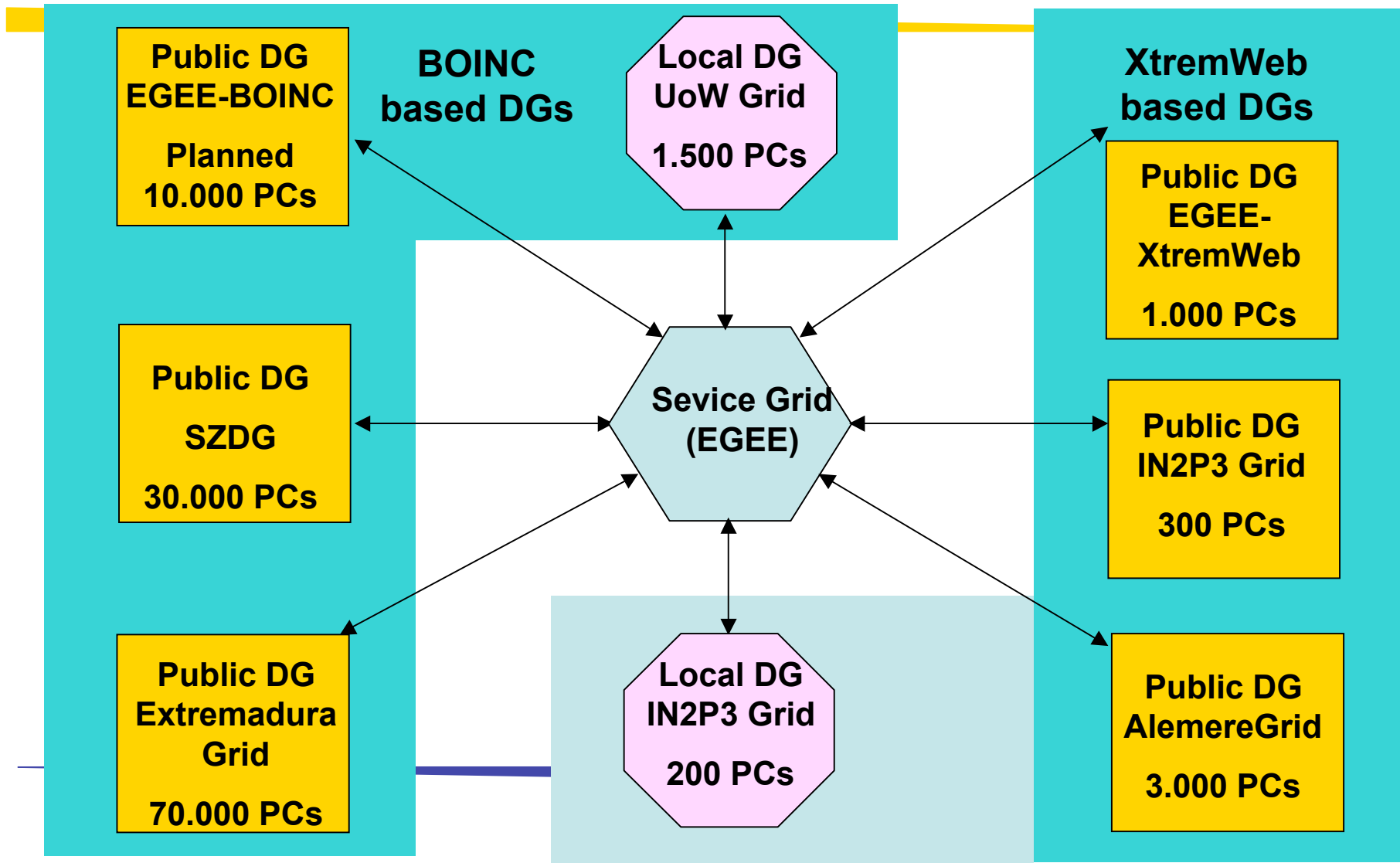



Seamless workflow development and execution environment

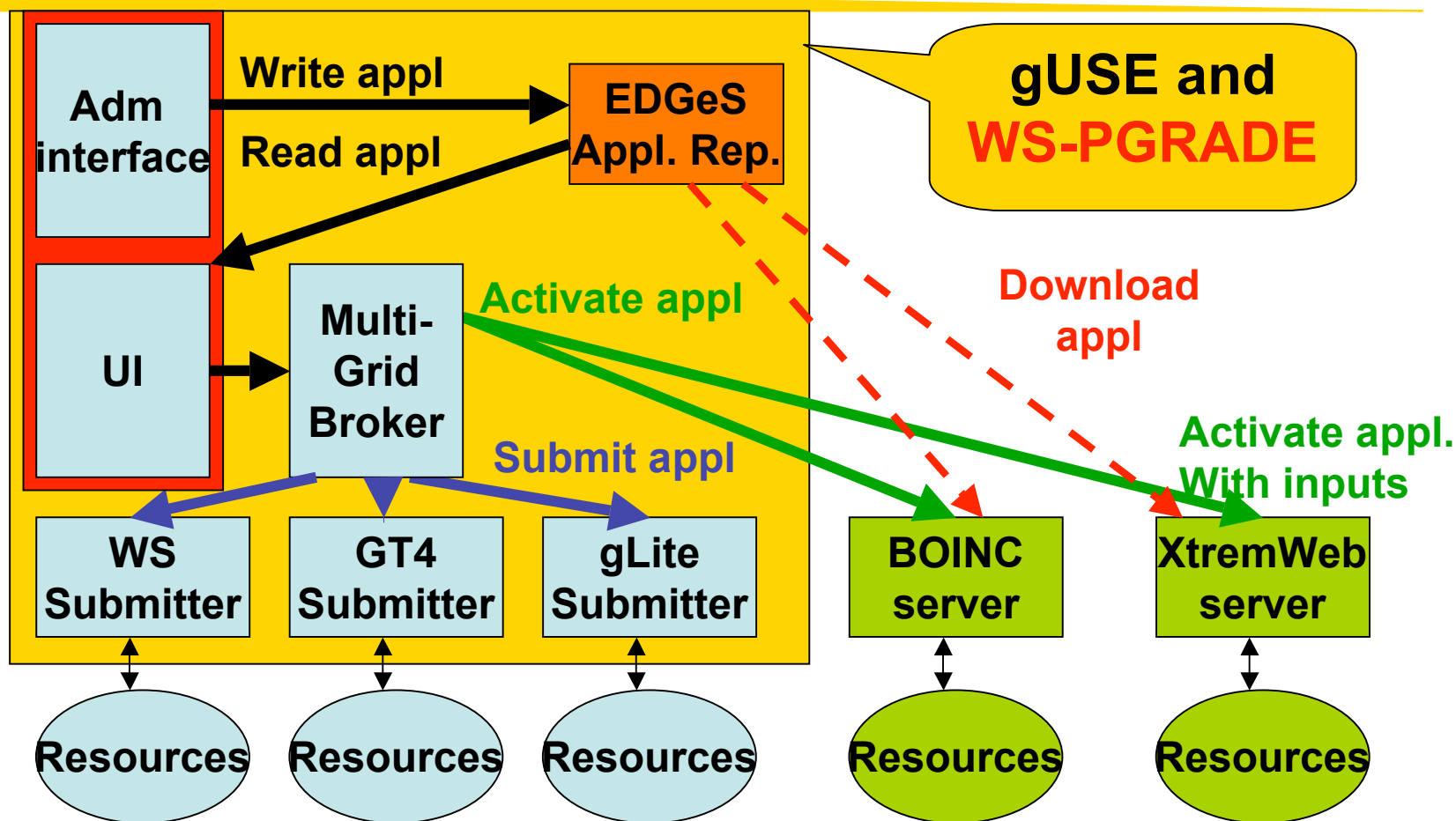

An example: CancerGrid workflow

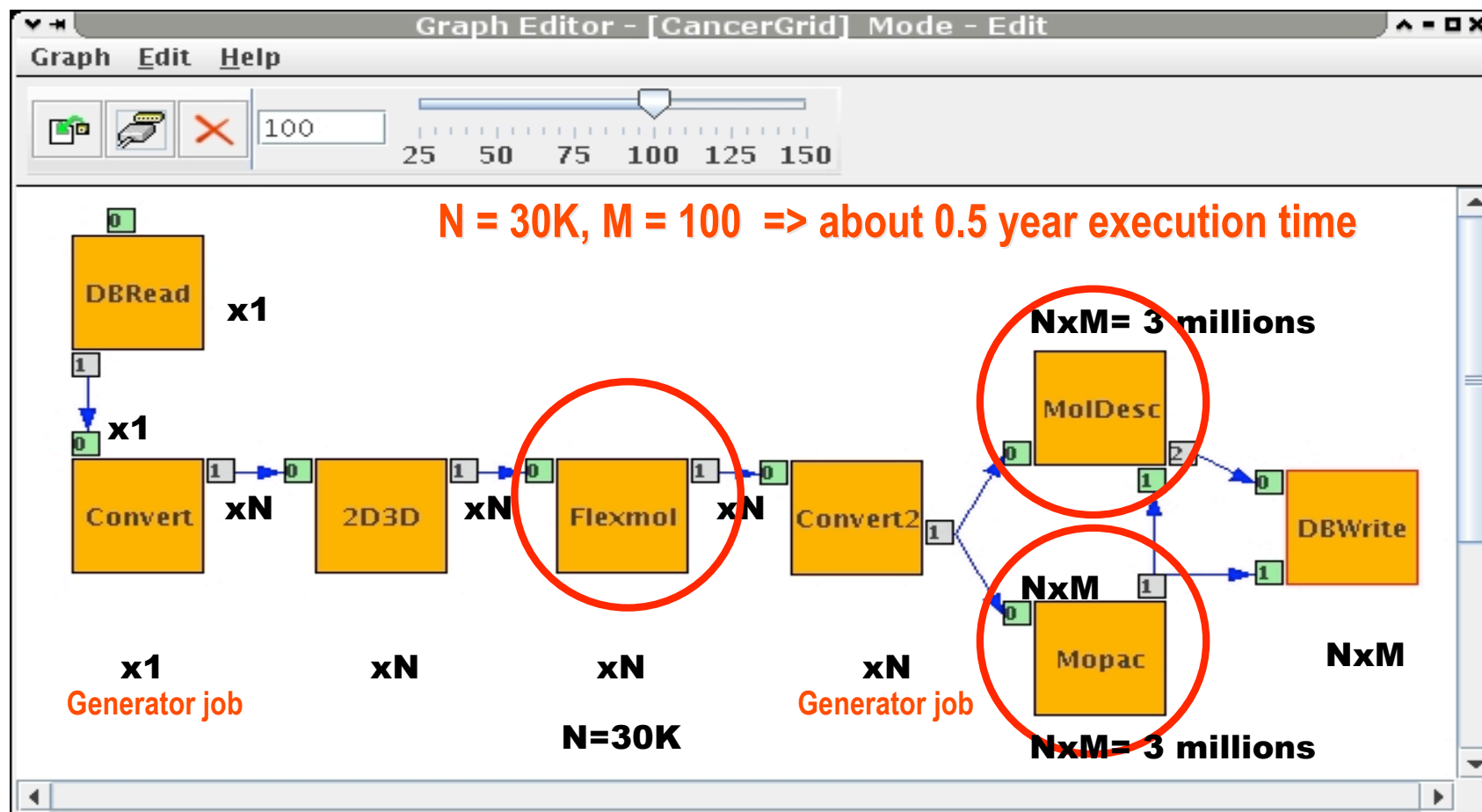

Cloud computing support

gUSE can provide the transparent access of SGs and DGs

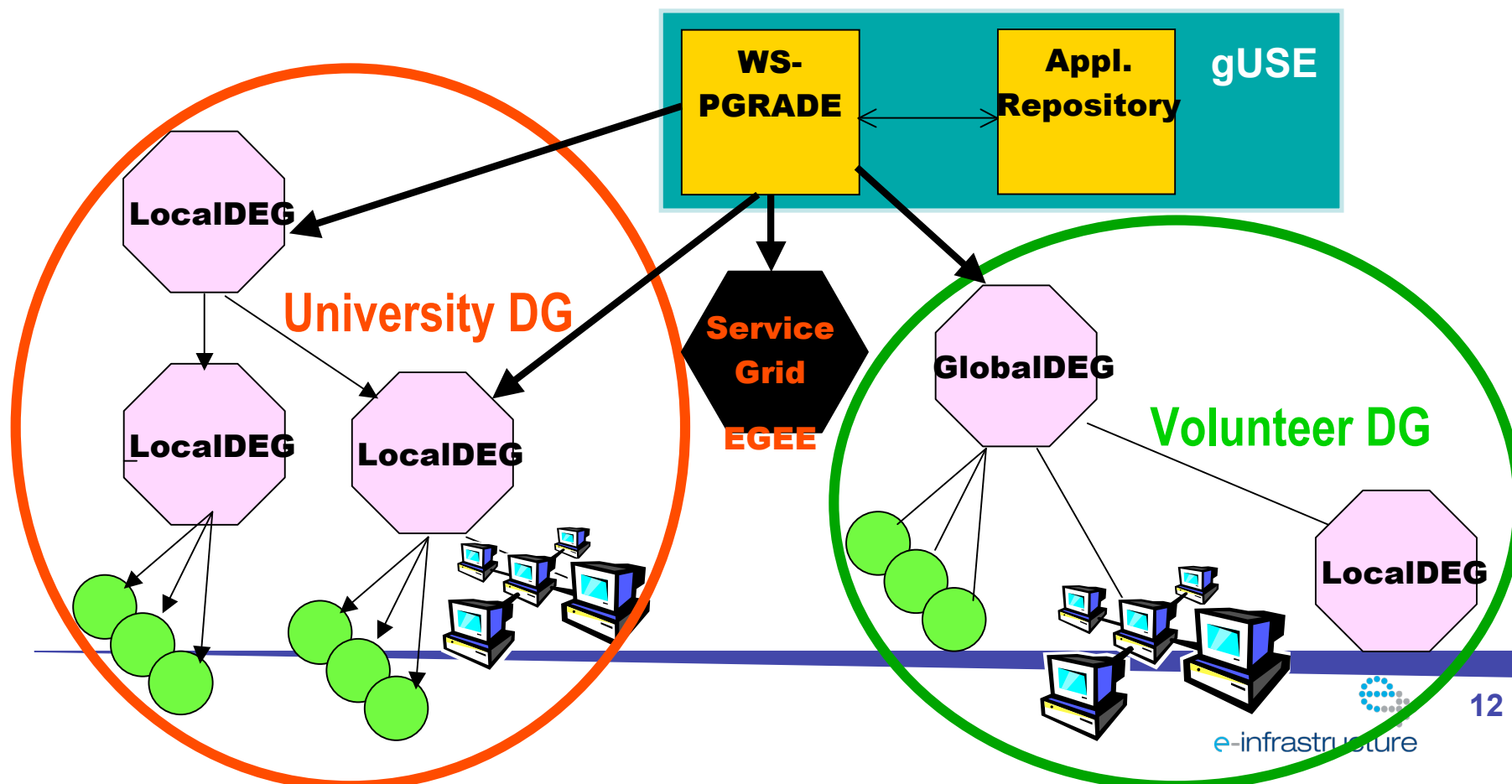



User communities

- Another goal of EDGeS
 - To identify user communities that need such large computational infrastructure
 - To support these communities in porting their application to EDGeS
- 14 identified communities:
 - BioInfoGrid, e-Health, Fusion, computational chemists, etc.
 - 4 new partners
- Establishing **EDGeS User Forum**
- 5 identified companies
 - 3 new partners
- Establishing **EDGeS Industry Forum**



Summary

EDGeS project

- will establish the integrated SG-DG infrastructure as **production service**
- Conduct **research** to solve open issues & problems
- Will supports **user communities**
- Within OGF will establish a new Research Group for **standardization** of interconnection of SG and DG systems
- Anyone who is interested in working on these issues is welcome to participate in the work of the
 - OGF RG
 - EDGeS User Forum
 - EDGeS Industry Forum
- <http://www.edges-grid.eu/>